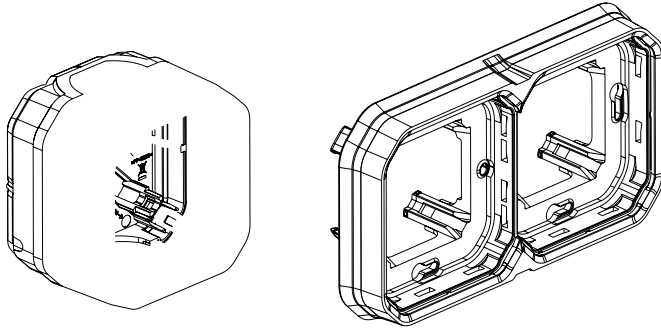

Plexo™
Surface-mounting box and support frame**Cat. No(s): 0 696 01L/02L/03L/06L/07L/08L/09L/10L/28L**
0 696 51L/52L/56L/68L/72L/80L/81L/82L/83L
0 696 86L/87L/88L/89L/90L/92L/93L/94L/98L
0 698 46L/53L/63L/66L/67L/90L**1. USE**

Waterproof equipment system intended for residential and professional technical locations (garages, cellars, car parks, workshops and industrial kitchens, etc.) as well as outdoor environments (terraces, gardens, campsites, etc.).
Box with membrane glands or cable glands and support frames .
To be equipped with modular Plexo™ mechanisms.

2. RANGE

3. OVERALL DIMENSIONS (mm) (continued)

■ Flush-mounting

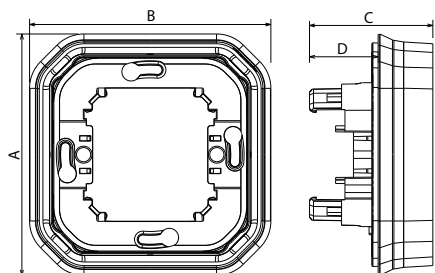

	A	B	C	D
1-gang	85.1	85.1	43.5	24.2
2-gang	85.1	156.2	43.5	24.2
3-gang	85.1	227.2	43.5	24.2

■ Flush-mounting with claws

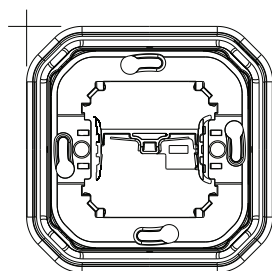

4. TECHNICAL CHARACTERISTICS

■ 4.1 Material characteristics

Box, support: PP reinforced

Front plate, rocker: ABS

Entry gland, cover plate: PP + SEBS

UV-resistant

Halogen-free

Resistance to salt spray: 7 days (168 h)

Self-extinguishing:

850°C/30 s for insulating components holding live parts in place.

650°C/30 s for other insulating components.

■ 4.2 Climate characteristics

Usage temperature: - 10° à + 40° C

Storage temperature: - 25° C à + 60° C

■ 4.3 Specific installation characteristics

Specific installation in case of condensate drain:

Creation of drainage holes with a diameter of 6mm at the places indicated according to the direction of assembly.

Be careful however when drilling the side hole, just cross the outer partition.

_ Implementation of cable glands:

Pre-drilling with a screwdriver, insertion of the cable or tube, pulling in the opposite direction to insertion to reveal the flexible zone on the outside of the end piece.

5. CLEANING

Surface cleaning with a cloth.

Do not use: acetone, tar remover, trichloroethylene.

Maintenance with the following products: Hexane (EN 60669-1),

Methylated spirit, Soapy water, Diluted ammonia, Bleach diluted to 10%, Window-cleaning products, Pre-saturated wipes.

6. STANDARDS AND APPROVALS

Compliance with standards of installation and manufacturing.

Refer to e. catalogue.